

# Single Stage Regulators

\*Flange gaskets, bolts, nuts and washers are not included.

## Range Specification

Inlet Pressure	0.07~1.56MPa	Outlet Pressure	2.30~3.30kPa
Lockup Pressure	≤3.50kPa	Safety Relief Valve Working Pressure	5.60~8.40kPa

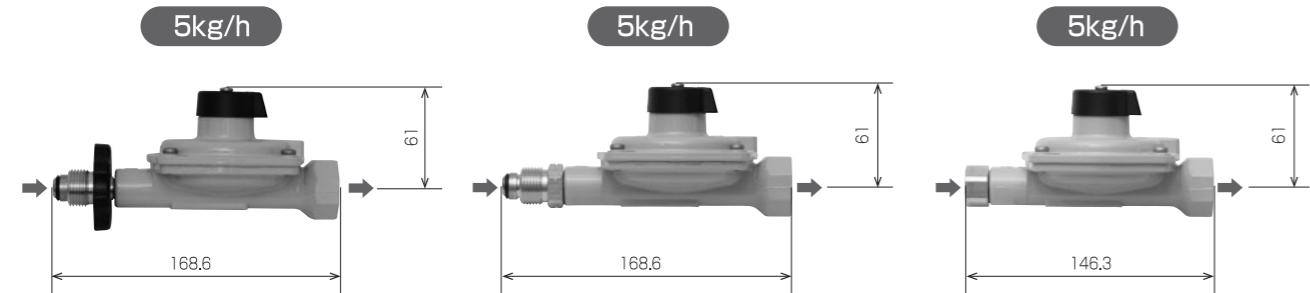

<b>HS-5B (H)</b>		<b>HS-5B (S)</b>		<b>HS-5B (Rc1/4)</b>	
Inlet	JIS POL Handwheel	Inlet	JIS POL Mechanical	Inlet	Rc1/4
Outlet	Rc1/2	Outlet	Rc1/2	Outlet	Rc1/2

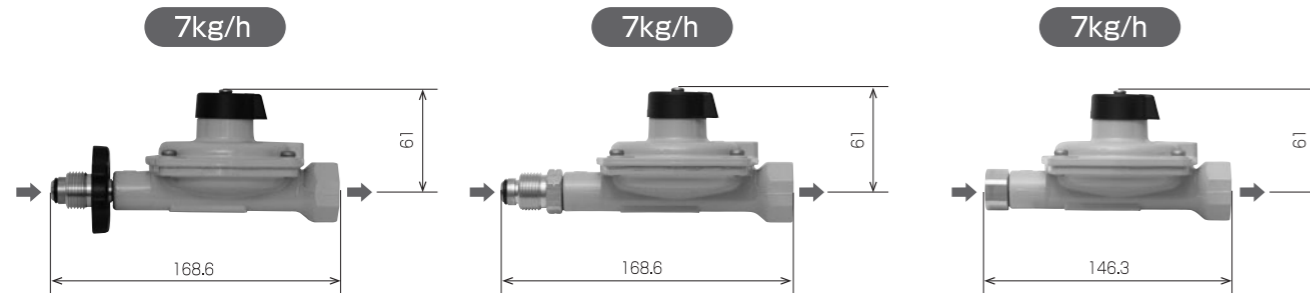

<b>HS-7A (H)</b>		<b>HS-7A (S)</b>		<b>HS-7A (Rc1/4)</b>	
Inlet	JIS POL Handwheel	Inlet	JIS POL Mechanical	Inlet	Rc1/4
Outlet	Rc1/2	Outlet	Rc1/2	Outlet	Rc1/2

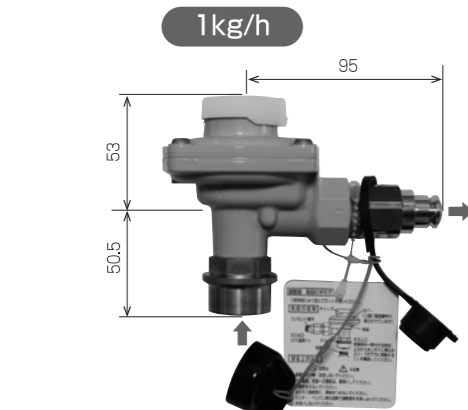

<b>SHT-1B</b>	
Inlet	Clip On Connector
Outlet	Quick Coupling Adapter

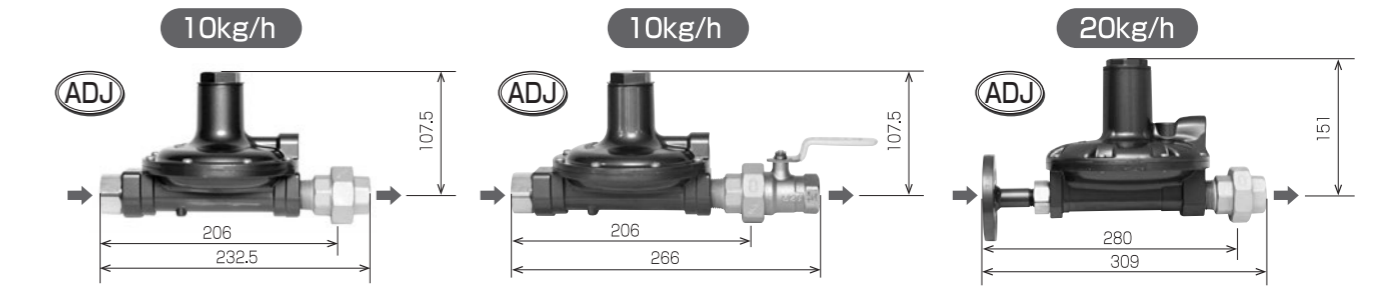

<b>C-10A-1</b>		<b>C-10A-1 (with BV)</b>		<b>C-20-1</b>	
Inlet	Rc1/2	Inlet	Rc1/2	Inlet	JIS20K15A Flange
Outlet	Rc3/4 Union	Outlet	Rc3/4 Ball Valve for Union	Outlet	Rc1 Union

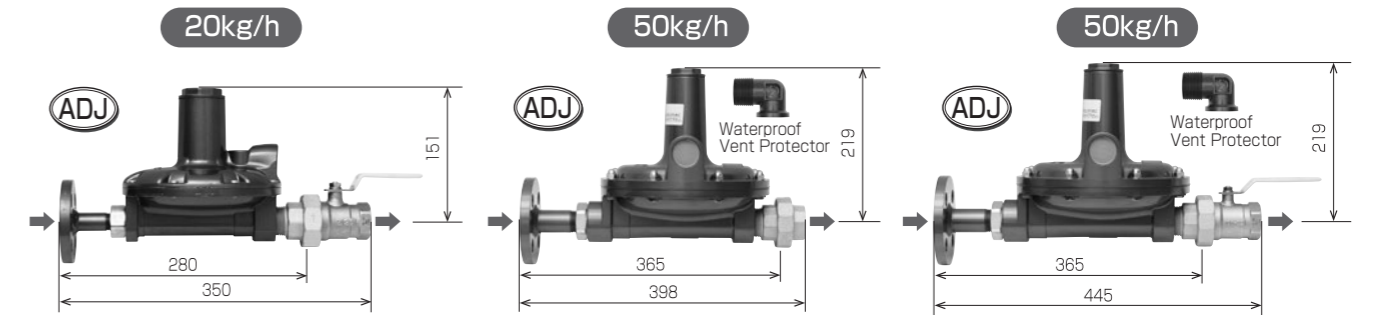

<b>C-20-1 (with BV)</b>		<b>GL-50-1</b>		<b>GL-50-1 (with BV)</b>	
Inlet	JIS20K15A Flange	Inlet	JIS20K25A Flange	Inlet	JIS20K25A Flange
Outlet	Rc1 Ball Valve for Union	Outlet	Rc1 1/4 Union	Outlet	Rc1 1/4 Ball Valve for Union

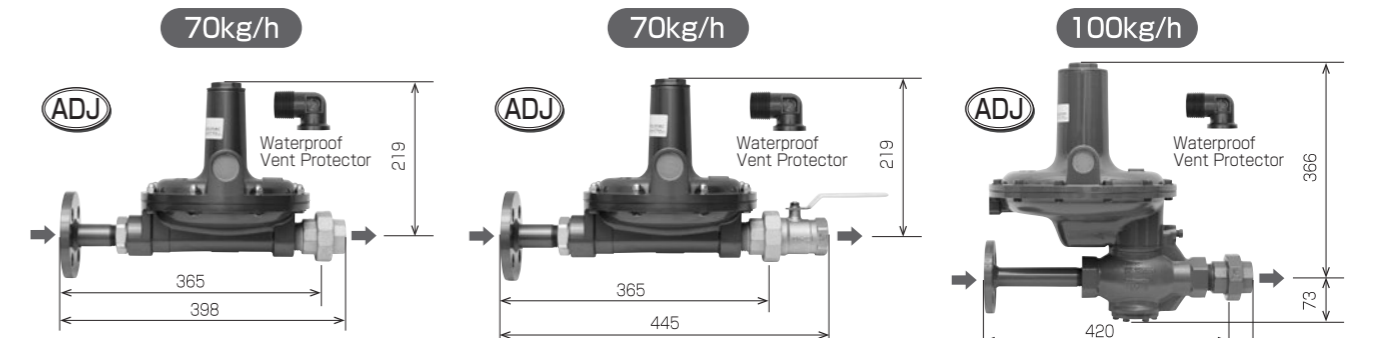

<b>GL-70-1</b>		<b>GL-70-1 (with BV)</b>		<b>G-32A-1</b>	
Inlet	JIS20K25A Flange	Inlet	JIS20K25A Flange	Inlet	JIS20K25A Flange
Outlet	Rc1 1/4 Union	Outlet	Rc1 1/4 Ball Valve for Union	Outlet	Rc1 1/2 Union

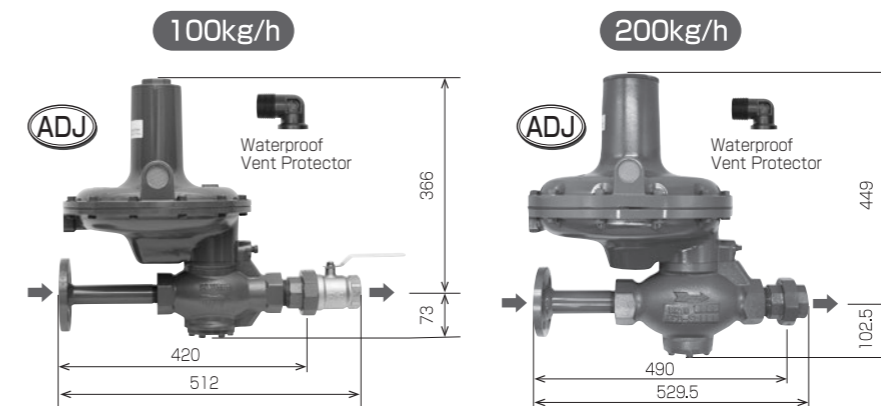

<b>G-32A-1 (with BV)</b>		<b>G-36C-1</b>	
Inlet	JIS20K25A Flange	Inlet	JIS20K40A Flange
Outlet	Rc1 1/2 Ball Valve for Union	Outlet	Rc2 Union

# First Stage Regulators

\*Flange gaskets, bolts, nuts and washers are not included.

## Range Specification

Inlet Pressure	0.10~1.56MPa	Outlet Pressure	0.057~0.083MPa	Lockup Pressure	≤0.095MPa
----------------	--------------	-----------------	----------------	-----------------	-----------



CM-100

Inlet	JIS20K15A Flange
Outlet	JIS10K15A Flange

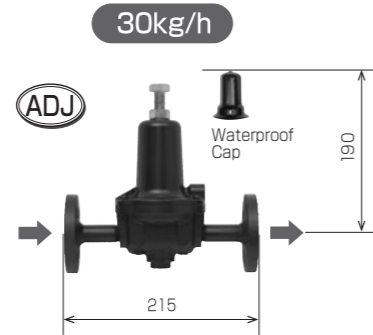

CM-100A

Inlet	JIS20K15A Flange
Outlet	JIS10K15A Flange



CM-100A (without Flange)

Inlet	Rc 1/2
Outlet	Rc 1/2

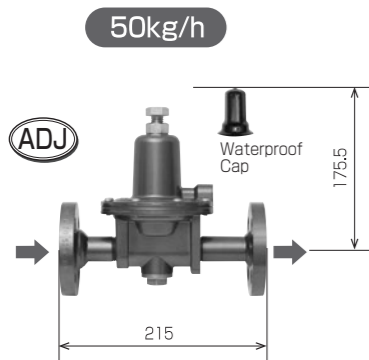

GM-50

Inlet	JIS20K20A Flange
Outlet	JIS10K20A Flange



GMF-70

Inlet	JIS20K20A Flange
Outlet	JIS10K20A Flange



GMF-100

Inlet	JIS20K25A Flange
Outlet	JIS10K25A Flange

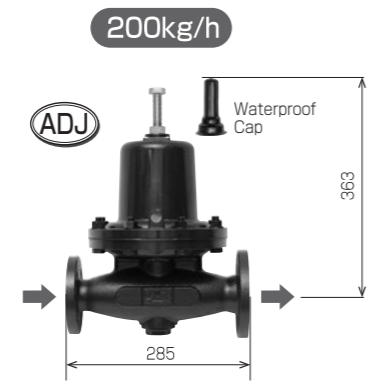

GMF-200

Inlet	JIS20K25A Flange
Outlet	JIS10K40A Flange



GMF-300

Inlet	JIS20K40A Flange
Outlet	JIS10K40A Flange



GMF-400

Inlet	JIS20K50A Flange
Outlet	JIS10K50A Flange



GMF-500

Inlet	JIS20K50A Flange
Outlet	JIS10K50A Flange

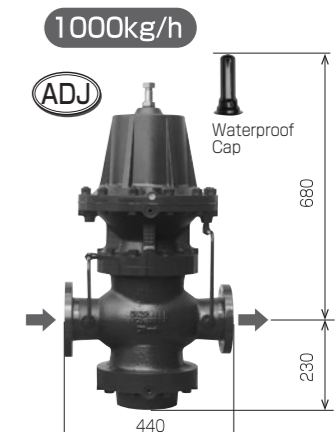

GM-1000

Inlet	JIS20K80A Flange
Outlet	JIS10K80A Flange

## For 0.30MPa Outlet Range Specification

Inlet Pressure	0.40~1.56MPa	Outlet Pressure	0.24~0.36MPa	Lockup Pressure	≤0.39MPa
----------------	--------------	-----------------	--------------	-----------------	----------



CM-100 3K

Inlet	JIS20K15A Flange
Outlet	JIS10K15A Flange

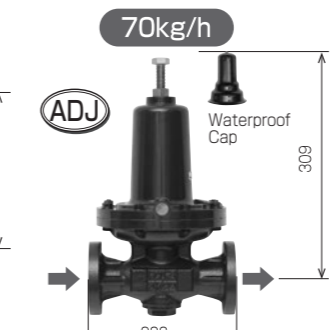

GMF-70 3K

Inlet	JIS20K20A Flange
Outlet	JIS10K20A Flange

## For Vaporiser (SMV) Range Specification

Inlet Pressure	0.07~0.96MPa	Outlet Pressure	0.032~0.083MPa	Lockup Pressure	≤0.095MPa
----------------	--------------	-----------------	----------------	-----------------	-----------

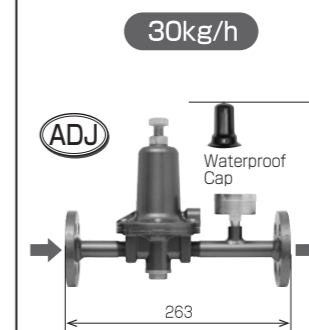

CM-30VS

Inlet	JIS10K15A Flange
Outlet	JIS10K15A Flange

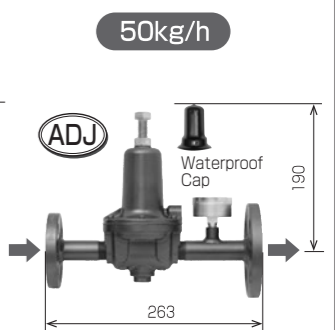

CM-50VS

Inlet	JIS10K20A Flange
Outlet	JIS10K25A Flange

## For Vaporiser Range Specification

Inlet Pressure	0.10~1.56MPa	Outlet Pressure	0.032~0.083MPa	Lockup Pressure	≤0.095MPa
----------------	--------------	-----------------	----------------	-----------------	-----------



CM-50V

Inlet	JIS20K20A Flange
Outlet	JIS10K20A Flange



CM-50V (without Flange)

Inlet	Rc3/4
Outlet	Rc3/4

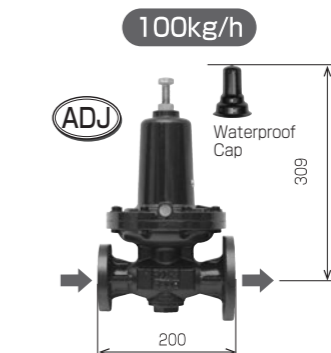

GMF-100V

Inlet	JIS20K20A Flange
Outlet	JIS10K25A Flange



GMF-300V

Inlet	JIS20K25A Flange
Outlet	JIS10K40A Flange

# Second Stage Regulators

\*Flange gaskets, bolts, nuts and washers are not included.

## Range Specification

Inlet Pressure	0.025~0.10MPa	Outlet Pressure	2.30~3.30kPa	Lockup Pressure	≤ 3.50kPa	Safety Relief Valve Working Pressure	5.60~8.40kPa
----------------	---------------	-----------------	--------------	-----------------	-----------	--------------------------------------	--------------

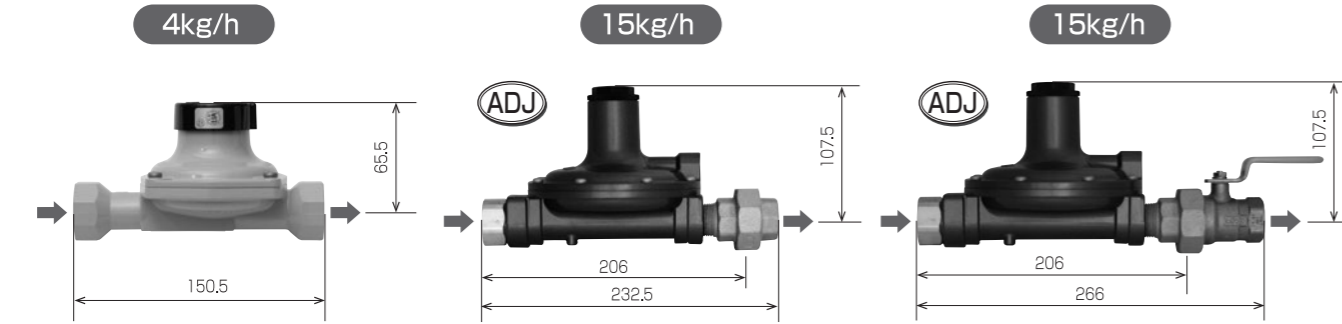

<b>H-4A-2</b>		<b>C-10A-2</b>		<b>C-10A-2 (with BV)</b>	
Inlet	Rc1/2	Inlet	Rc1/2	Inlet	Rc1/2
Outlet	Rc1/2	Outlet	Rc3/4 Union	Outlet	Rc3/4 Ball Valve for Union

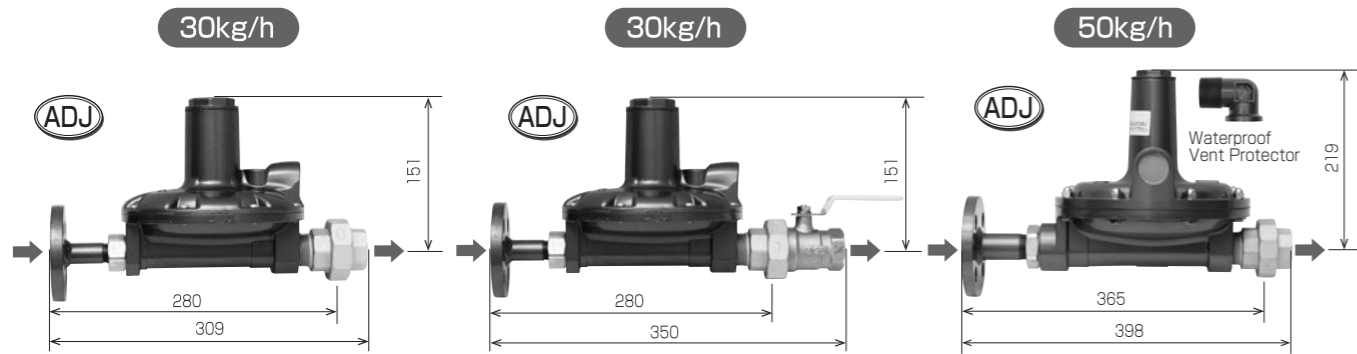

<b>C-20-2</b>		<b>C-20-2 (with BV)</b>		<b>GL-50-2</b>	
Inlet	JIS10K15A Flange	Inlet	JIS10K15A Flange	Inlet	JIS10K25A Flange
Outlet	Rc1 Union	Outlet	Rc1 Ball Valve for Union	Outlet	Rc1 1/4 Union

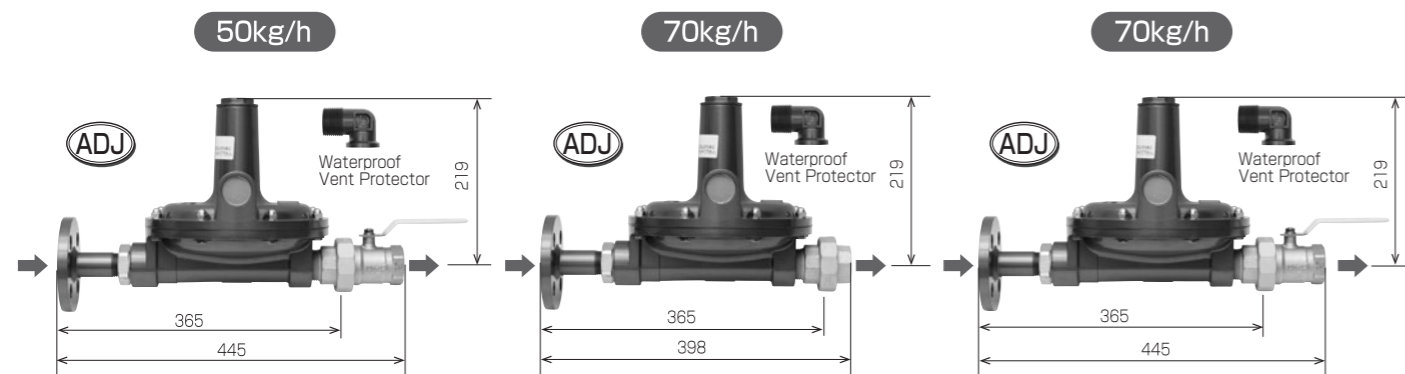

<b>GL-50-2 (with BV)</b>		<b>GL-70-2</b>		<b>GL-70-2 (with BV)</b>	
Inlet	JIS10K25A Flange	Inlet	JIS10K25A Flange	Inlet	JIS10K25A Flange
Outlet	Rc1 1/4 Ball Valve for Union	Outlet	Rc1 1/4 Union	Outlet	Rc1 1/4 Ball Valve for Union

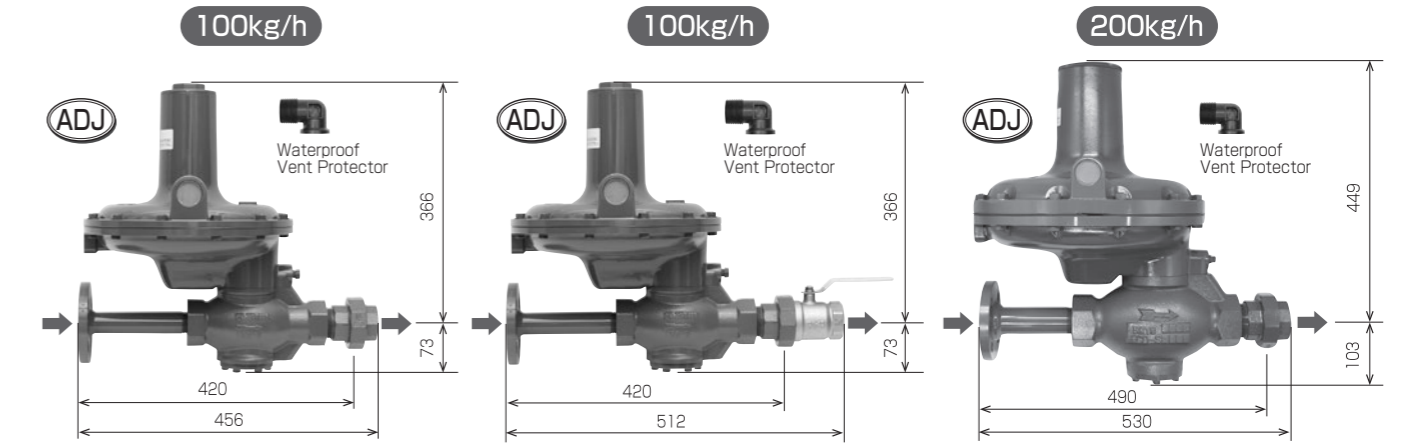

<b>G-32A-2</b>		<b>G-32A-2 (with BV)</b>		<b>G-36C-2</b>	
Inlet	JIS10K25A Flange	Inlet	JIS10K25A Flange	Inlet	JIS10K40A Flange
Outlet	Rc1 1/2 Union	Outlet	Rc1 1/2 Ball Valve for Union	Outlet	Rc2 Union

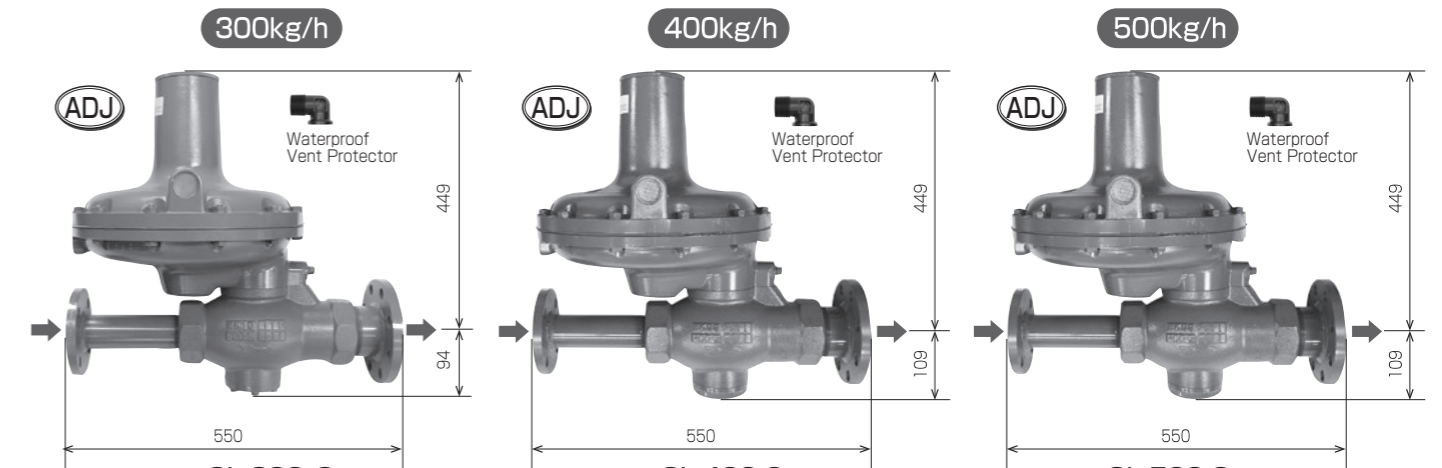

<b>GL-300-2</b>		<b>GL-400-2</b>		<b>GL-500-2</b>	
Inlet	JIS10K50A Flange	Inlet	JIS10K50A Flange	Inlet	JIS10K50A Flange
Outlet	JIS10K80A Flange	Outlet	JIS10K80A Flange	Outlet	JIS10K80A Flange

**6kg/h** Convertible to **5.5/m³/h in NG**

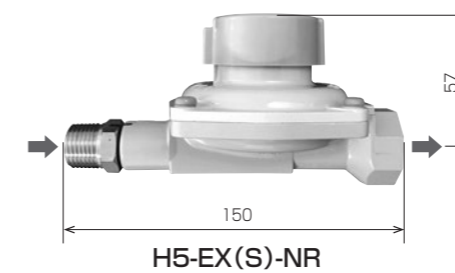

## Specifications

Gas Type	LPG	NG
Inlet Pressure	0.03~0.15 MPa	0.03~0.20 MPa
Outlet Pressure	2.52~3.4 kPa	1.84~2.48 kPa
Lockup Pressure	≤3.50kPa	≤2.70kPa
Inlet	R1/2	
Outlet	Rc1/2	

# Variable Type Pressure Regulators

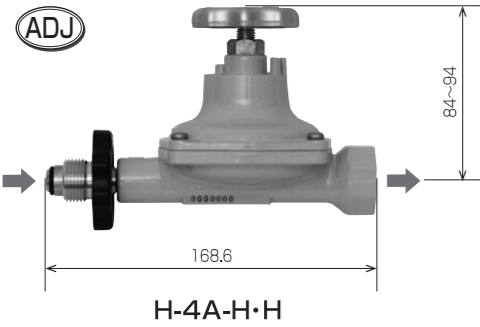

Model	H-4A-H·H
Capacity(Propane)	4kg/h
Inlet Pressure	0.07~1.56MPa
Variable Outlet Pressure Range	4.50~7.00kPa
Outlet Pressure	Set Point±20% kPa
Lockup Pressure	≤Set Point+30% kPa
Safety Relief Valve Working Pressure	Set Point + 4.30~4.80kPa
Inlet Connection	JIS POL with Handwheel
Outlet Connection	Rc 1/2

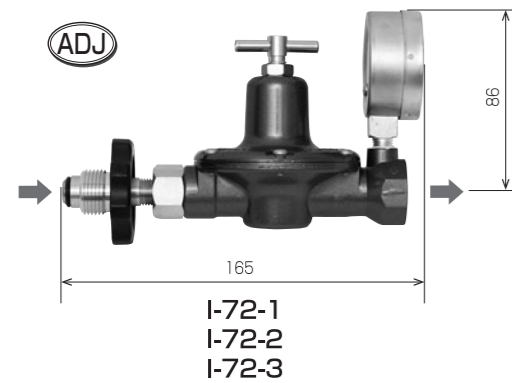

Model	I-72-1	I-72-2	I-72-3
Capacity(Propane)	5kg/h		
Inlet Pressure	0.13~1.56MPa	0.17~1.56MPa	0.40~1.56MPa
Variable Outlet Pressure Range	0.01~0.07MPa	0.01~0.16MPa	0.01~0.35MPa
Outlet Pressure	Set Point±20% MPa		
Lockup Pressure	≤Set Point+30% MPa		
Inlet Connection	JIS POL with Handwheel		
Outlet Connection	Rc 1/2		

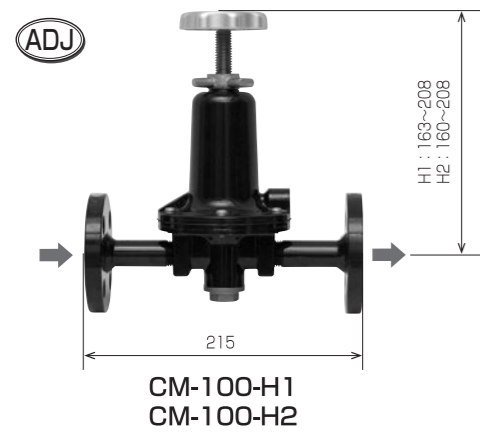

Model	CM-100-H1	CM-100-H2
Capacity(Propane)	30kg/h	
Inlet Pressure	0.10~1.56MPa	0.07~0.40MPa
Variable Outlet Pressure Range	0.03~0.15MPa	0.00~0.04MPa
Outlet Pressure	Set Point±20% MPa	
Lockup Pressure	≤Set Point+30% MPa	
Inlet Connection	JIS20K 15A Flange	
Outlet Connection	JIS 10K 15A Flange	

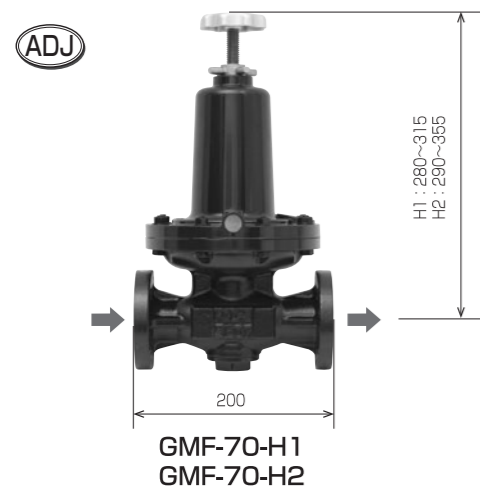

Model	GMF-70-H1	GMF-70-H2
Capacity(Propane)	70kg/h	
Inlet Pressure	0.10~1.56MPa	0.07~0.40MPa
Variable Outlet Pressure Range	0.03~0.15MPa	0.00~0.04MPa
Outlet Pressure	Set Point±20% MPa	
Lockup Pressure	≤Set Point+30% MPa	
Inlet Connection	JIS20K20A Flange	
Outlet Connection	JIS 10K20A Flange	

# Second Stage Regulators Incorporating Leakage Detecting System

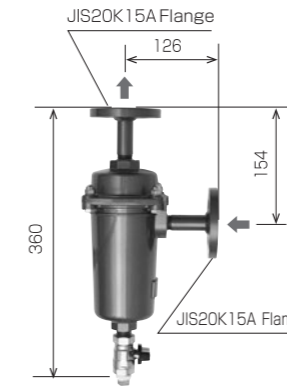
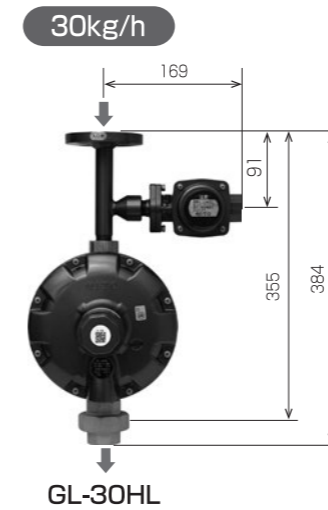

**Drainage Trap DPM-15A**  
Supplied by ITO.  
Painted grey

Model	GL-30HL	
Capacity(Propane)	30kg/h	
Inlet Pressure	0.025~0.15MPa	
Outlet Pressure	2.30~3.30kPa	
Lockup Pressure	≤ 3.50kPa	
Safety Relief Valve Working Pressure	5.60~8.40kPa	
Minimum Working Flow Rate of Main Regulator	0.4±0.38kg/h	
Maximum Flow Rate of Sub Regulator	0.5kg/h	
Inlet Connection	JIS 10K 15A Flange	
Outlet Connection	Main Reg. Rc 1 Union	Sub Reg. Rc 1/2

\*See page 97 regarding gas flow recorders.

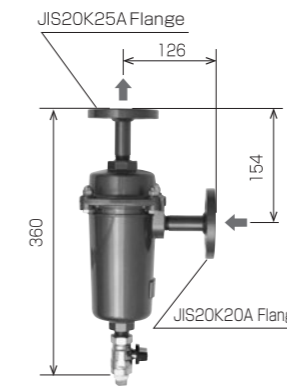
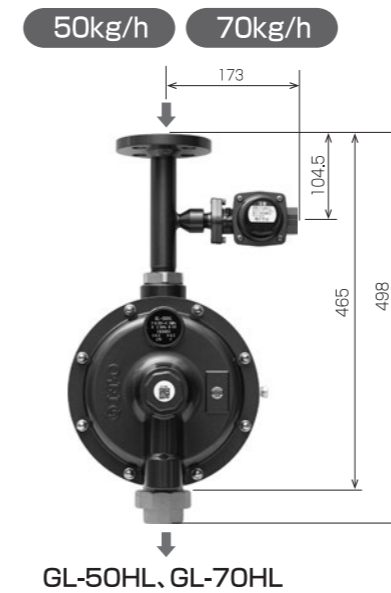

**Drainage Trap DPM-20A**  
Supplied by ITO.  
Painted grey

Model	GL-50HL	GL-70HL
Capacity (Propane)	50kg/h	70kg/h
Inlet Pressure	0.025~0.15MPa	
Outlet Pressure	2.30~3.30kPa	
Lockup Pressure	≤ 3.50kPa	
Safety Relief Valve Working Pressure	5.60~8.40kPa	
Minimum Working Flow Rate of Main Regulator	0.4±0.38kg/h	
Maximum Flow Rate of Sub Regulator	0.5kg/h	
Inlet Connection	JIS 10K 25A Flange	
Outlet Connection	Main Reg. Rc 1 1/4 Union	Sub Reg. Rc 1/2

\*See page 97 regarding gas flow recorders.

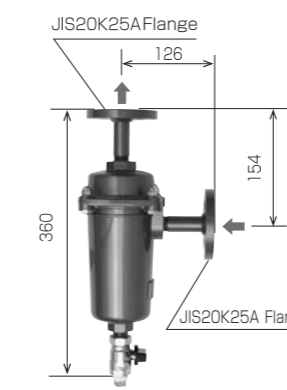
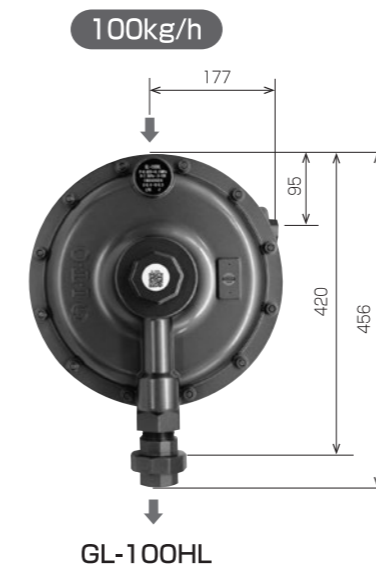

**Drainage Trap DPM-25A**  
Supplied by ITO.  
Painted grey

Model	GL-100HL	
Capacity(Propane)	100kg/h	
Inlet Pressure	0.025~0.15MPa	
Outlet Pressure	2.30~3.30kPa	
Lockup Pressure	≤ 3.50kPa	
Safety Relief Valve Working Pressure	5.60~8.40kPa	
Minimum Working Flow Rate of Main Regulator	0.4±0.38kg/h	
Maximum Flow Rate of Sub Regulator	0.5kg/h	
Inlet Connection	JIS 10K 25A Flange	
Outlet Connection	Main Reg. Rc 1 1/2 Union	Sub Reg. Rc 1/2

\*See page 97 regarding gas flow recorders.